

Olympia NOVANTADUE
Agg. 15/10/09

Art.01 70 - 02 70 Kg. 20 - 21
Vaso scarico S a pavimento
Wc bowl trap for vertical drain floor
Vaso scarico P a parete
Wc bowl trap for horizontal drain wall

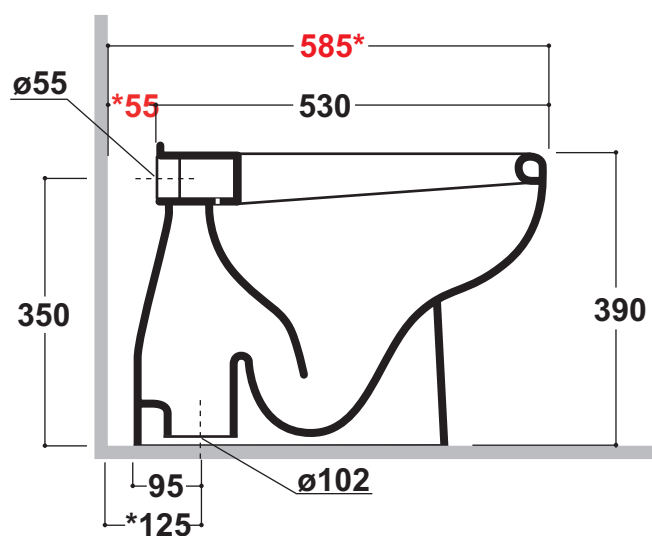

***Quota di installazione consigliata**
Advised measure for installation

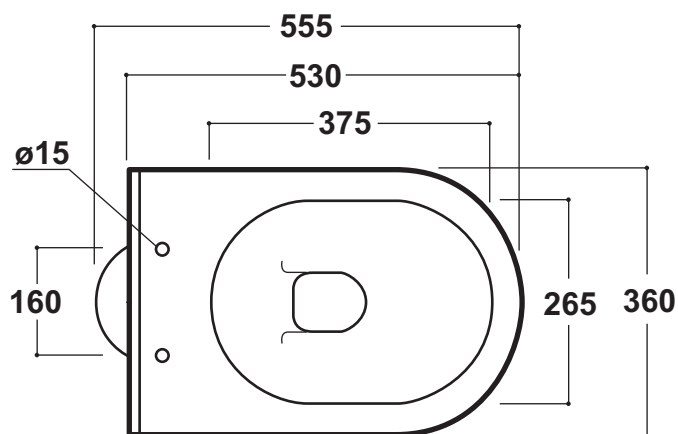